



Bray[®]

THE
HIGH
PERFORMANCE
COMPANY

PRESENTS THE ULTIMATE
HIGH PERFORMANCE VALVE

**BRAY / McCANNALOK
SERIES 40**

**HIGH PERFORMANCE
HIGH PRESSURE
HIGH TEMPERATURE
ZERO LEAKAGE
BUTTERFLY VALVES**

2 1/2" - 42" (65-1050mm)

**STANDARD WAFER
& LUG BODIES OFFER
BIDIRECTIONAL SHUT-
OFF AT FULL RATED
ANSI CLASS 150, 300
& 600 OPERATING
PRESSURES**

**TEMPERATURE RANGE:
-20°F TO 500°F (-29°C
TO 260°C)**

**SERIES 40/41 - ANSI CLASS 150
SERIES 42/43 - ANSI CLASS 300
SERIES 44/45 - ANSI CLASS 600**

Bray Controls is proud to offer the Bray/McCannalok line of high performance butterfly valves. This product line is recognized as a proven leader with over 25 years of successful service in process industries worldwide. The Series 40's unique, patented design received *Chemical Processing's* Valor Award for Best Product shortly after it was introduced. The simple, innovative design offers rugged reliability and extremely easy maintenance in the field. Independent and internal tests have proven Bray/McCannalok's superior service life capability, with bubble-tight shut-off through over 100,000 cycles.

The Series 40 valves can be automated inexpensively with Bray's pneumatic and electric actuators.

When compared to gate, globe, ball, diaphragm and plug valves, the Bray/McCannalok butterfly valve is significantly smaller and lighter weight, therefore installation time and maintenance costs are greatly reduced.

The Bray/McCannalok High Performance Valve delivers the highest quality and highest value available for your requirements.

BODY (A)

One piece wafer body style or lug style for dead-end service. Both body styles offer bidirectional sealing as standard to full ANSI Class 150, 300 or 600 ratings. Standard body materials are either carbon steel or stainless steel for excellent corrosion resistance. Extended neck allows for 2" of pipeline insulation and easy access to stem packing adjustments and actuator mounting.

STEM (B)

The high-strength, one piece stem is 17-4 PH Stainless Steel. The output shaft of the stem is standardized for interchangeability of Bray actuators.

DISC (C)

The disc has been engineered to maximize flow and minimize resistance, providing a high C_v. 316 Stainless Steel is standard.

TAPER PINS (D)

Taper pins are precision fit into drilled, taper-reamed holes providing a positive connection of maximum strength between the valve disc and stem.

INTERNAL TRAVEL STOP (E)

An internal travel stop has been designed to prevent over travel of the disc, minimizing possible seat damage.

HANDLE AND INDEX PLATE (F)

The heavy-duty, spring release handle and notched index plate allow for positioning the valve disc to precise angle stops between the full open and full closed positions.



ADJUSTABLE STEM PACKING

The stem packing system features easy access to adjusting hex head nuts without requiring removal of the actuator. The system consists of a gland ring (G), a gland retainer (H), studs, hex head nuts and lock washers (I). A slight 1/4 turn of the hex head nuts is usually all that is required should field adjustment ever be needed. Both hex head nuts must be evenly adjusted and not overtightened.

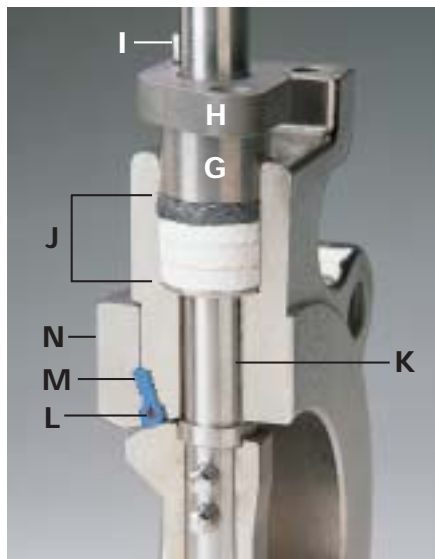

STEM SEAL (J)

The stem seal system provides constant compression for a positive seal around the stem. PTFE packing seals the stem, and a carbon fiber anti-extrusion ring contains the packing. Flexible graphite rings are available for high temperature applications and are standard on fire safe valves.

All Class 150 and 3"-12" Class 300 valves have one set of stem seal packing rings and a stem locating plug with an O-ring seal in the body base. 14"-30" Class 300 and all Class 600 valves have upper and base twin stem seals which balance axial forces on the stem and disc under all operating conditions, and eliminate any piston effect on the stem.

STEM BEARINGS (K)

Top and bottom bearings, consisting of a 316 Stainless Steel shell with a TFE/glass fabric liner bearing surface, securely support the stem. The stem bearings provide excellent resistance to corrosion and distortion from high temperatures and mechanical loading forces.

SEAT DESIGN

THE HEART OF THE SERIES 40

VALVE The unique, two-part seat assembly consists of a resilient O-ring energizer (L) which is totally encapsulated by the RTFE* seat (M). The assembly is locked in the body recess by a full-faced seat retainer (N). This simple, reliable and proven combination results in many exclusive advantages, including:

- The O-ring energizer is completely isolated from all contact with the line media by the RTFE seat.
- Serrations in the seat retainer and body recess secure the seat assembly in place regardless of disc position.
- The full-faced retainer is bolted to the body, locking the seat in the correct position. The seat is secured even without the mating flange.
- The closely confined and well supported seat is energized by the disc and line pressure. The higher the pressure, the tighter the seal. In low pressure and vacuum applications, the energized seat offers superior sealing and longer service life than many other designs.
- Line media is sealed to zero leakage in both directions.
- The seat is self-adjusting for wear and temperature changes.
- Seat replacement is extremely easy – just remove the seat retainer, rotate the disc into the closed position and place a new seat assembly in the machined recess of the body. This simple procedure will not disturb the disc or stem.

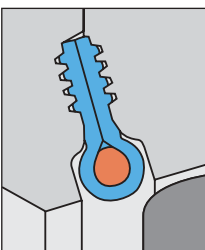

Seat non-compressed as disc approaches.

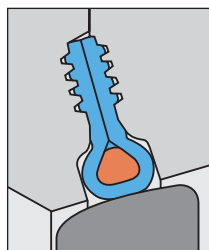

Disc in closed position; with no line pressure.

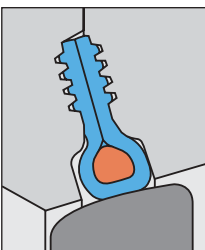

Disc in closed position; line pressure applied from the left.

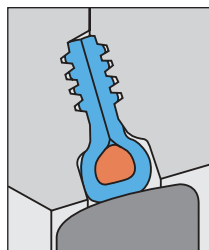

Disc in closed position; line pressure applied from the right.

DOUBLE OFFSET STEM AND DISC DESIGN

The double offset design of the Series 40 assures reduced seat wear and bidirectional, zero leakage, shut off throughout the full pressure range.

At the initial point of disc opening, the offset disc produces a cam-like action, pulling the disc from the seat. This cam-like action reduces seat wear and eliminates seat deformation when the disc is in the open position. When open, the disc does not contact the seat, therefore seat service life is extended and operating torques are reduced. As the valve closes, the cam-like action converts the rotary motion of the disc to a linear type motion to effectively push the disc onto the seat. The wiping action of the disc against the seat prevents undesirable material build-up from slurries or suspended solids.

The taper pins carry virtually equal loads while anchoring the disc to the stem, permitting accurate disc closure for consistent sealing and positive shut off.

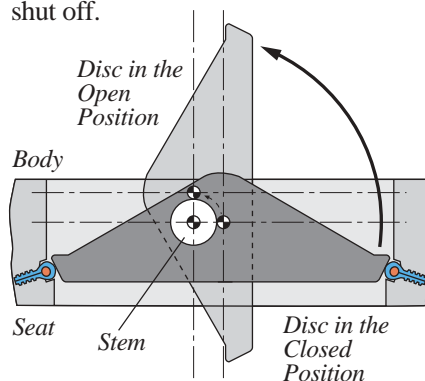

For over 25 years the reliability of the Bray/McCannalok has been conclusively proven, both in lab tests and thousands of field applications. After a test of over 100,000 cycles at 720 psi, the seat remained in excellent condition, continuing to provide a bidirectional bubble-tight seal. Even after more than 878,000 cycles at 2 psi, the Series 40 still sealed bubble-tight in both directions.

*RTFE is the common designation for RPTFE as supplied by Bray.

FIRE SAFE

**BRAY/McCANNALOK
HIGH PERFORMANCE
SERIES 40/41 VALVES
ARE AVAILABLE
WITH PROVEN FIRE
SAFE, BIDIRECTIONAL
FIRE SAFE SEATS
ON SIZES 2 1/2"-16" ANSI
150 AND 300 CLASS
WAFER & LUG BODIES**

FOR RELIABLE CONTROL
OF FLAMMABLE AND
HAZARDOUS FLUIDS
IN PETROLEUM,
PETRO-CHEMICAL,

CHEMICAL AND OTHER HIGH-RISK
APPLICATIONS, THE FIRE SAFE
COMBINES SUPERIOR PERFOR-
MANCE, EXTENDED SERVICE LIFE
AND COMPLIANCE WITH THE MOST
DEMANDING WORLDWIDE
FIRE-TEST STANDARDS – BEFORE,
DURING AND AFTER A FIRE!

In normal service, the FIRE SAFE combina-
tion resilient/metal seat seals bubble-tight
in both directions of line media flow
through the full rated pressure and tem-
perature ranges. When closed, the disc
remains compressed against the resilient
mechanically loaded seat, which is securely
locked in place by a full-faced retainer.
Line media pressure strengthens the seal.

In the event of a fire, if excessive heat
destroys the resilient seat materials, either
partially or completely, the seat provides
a constant metal-to-metal backup seal.

In real-world fire conditions, line
pressure is immediately reduced and the
entire area is hosed down. The resulting
pressure drop and rapid cool down causes
many valves to fail. The FIRE SAFE design
does not rely on line media pressure to
seal, therefore the valve offers superior
low pressure performance than competitive
designs. The Inconel® metal seat functions
as a spring mechanism, which allows for
expansion and contraction without break-
ing contact with the disc. Additionally,
the Inconel seat offers better corrosion and
heat resistance and greater strength than
the stainless steel seats commonly used.

The Bray/McCannalok delivers proven
fire safe protection not only in the lab, but
also where it counts the most – in the field.



The adjustable stem sealing packing
system is composed of flexible graphite
and formed graphite rings. These ring
materials offer maximum stem sealing
capability. The packing can be easily
adjusted by a slight turn of the readily
accessible hex head nuts.



FIRE-TEST STANDARDS API 607 4th Edition Certified.

**The Bray/McCannalok FIRE
SAFE has been thoroughly
tested and meets or exceeds
the latest international fire test
standards. Since its introduction
the FIRE SAFE has passed field
applications and lab tests with
flying colors, delivering superior
performance under the most
demanding conditions.**

FIRE SAFE SEAT OPERATION

The seat assembly in normal service con-
tacts the disc with both the resilient seat
material and metal seat. During and after
a fire, when the resilient material has
been partially or completely destroyed,
the metal seat provides a positive seal by
remaining in constant contact with the
disc in either direction of media flow.

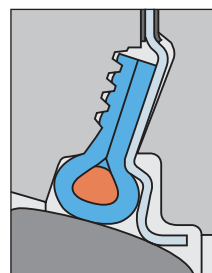

*The FIRE SAFE Seat
in normal service*

*Bidirectional
Resilient Seat with
O-ring Energizer /
Inconel® Seat*

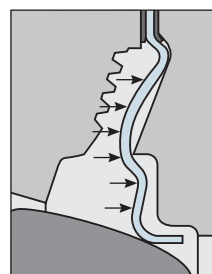

*Seat after fire, with
disc sealing load and
line media pressure
acting on the seat
from the left. (Seat
retainer downstream)*

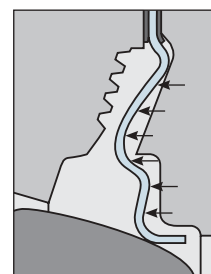

*Seat after fire, with
disc sealing load and
line media pressure
acting on the seat
from the right. (Seat
retainer upstream)*

*Inconel® is a registered trademark of Inco Alloys International, Inc.

Bray/McCannalok Series 40 valves handle a wide range of conditions and media, such as corrosive chemicals, water, gases, acids, alkalies, hydrocarbons plus many other fluids. Bray's standard valve line has been specifically designed to meet most applications. When applications demand special requirements, Bray offers valves and materials that meet these needs. Services and optional materials include:

VACUUM

Standard Series 40 valves with TFE seats are recommended for vacuum service down to .02 mm Hg absolute pressure, or 20 microns. For vacuum service down to 1×10^{-3} mm Hg absolute pressure, or 1 micron, specially prepared valves are recommended. Under certain conditions, these valves serve well in the high vacuum range down to 1×10^{-6} mm Hg absolute pressure.

STEAM

Series 40 valves are specifically designed for a wide range of high temperature and high pressure applications including on-off and modulating control of hot water, condensed water or chilled water. The Series 40 valve is rated 150 psi (10.3 bar) saturated steam at 366°F (185°C) for on-off applications. For modulating service, the Series 40 is rated 50 psi at 300°F. Use of the standard RTFE seat is recommended for this service.

DRY CHLORINE – Gas or Liquid

Special materials as well as assembly and testing procedures are applied to assure bubble-tight closure in these critical services.

Please consult your Bray representative for specific recommendations regarding your requirements.



ASH HANDLING AND ABRASIVE

For applications where flow velocity and differential pressure are low, RTFE or UHMWPE seats and electroless nickel plated discs are recommended. For applications requiring improved resistance to wear and particles of higher hardness, a stellite faced disc and FIRE SAFE design are recommended.

CAUSTIC

Valve materials must be selected for sufficient corrosion requirements. Stainless steel is recommended for sodium and potassium hydroxide applications.

HEATING, VENTILATION AND AIR CONDITIONING (HVAC)

Series 40 valves can be used for damping or balancing water flow, main stop valves, block valves, throttling valves, and control of pump suction or discharge.

OXYGEN

Series 40 valves for critical gaseous oxygen service are specially prepared, cleaned, inspected, assembled and tested to ensure removal of all burrs, sharp edges, dirt, hydrocarbon oil or grease, and other contaminants. Each valve is individually wrapped and sealed in polyethylene before shipment.

SOUR GAS

Selected materials of construction meeting NACE standards (MR-01-75) permit ready application and maximum serviceability in these difficult services.

DEAD-END SERVICE

Bray/McCannalok lug bodies for bidirectional dead-end service are offered as standard in full ANSI Class 150, 300 and 600 ratings.

COAST GUARD APPROVED

The Bray/McCannalok High Performance Valve has been approved for category A applications.

Series 40 valves can be optionally supplied in a number of different seat and body materials, including:

- PTFE seat and UHMWPE seat with resilient O-ring energizer.
- Fluorosilicone inner O-rings for methylene chloride service.
- FIRE SAFE graphite/carbon fiber or similar packing for fire safe or high temperature service.
- Hastelloy C bodies for hydrogen-cyanide service.
- Aluminum bronze bodies for marine environments.
- Longer stem lengths to accommodate differing control areas.
- Alloy 20 trim for sulfuric acid service.
- Monel discs for Chlorine service.
- Many other materials are also available, please consult the Bray factory.



ANSI 150 Series 40

Series 41 WEIGHTS

Valve Size ins	mm	A	B	C	D	E	F	G	H*	J	K	L	M	N	Lug Bolting Data			Series 40	Series 41
															BC	No. Holes	Threads UNC-2B		
2 1/2	65	4.75	1.88	2.28	3.00	4.29	3.81	.63	.43	3.34	2.44	1.56	.38	5/16-18	5.50	4	5/8-11	13	18
3	80	5.25	1.88	2.86	3.25	4.54	3.81	.63	.43	3.34	2.44	1.56	.38	5/16-18	6.00	4	5/8-11	15	19
4	100	6.72	2.03	3.72	4.38	5.41	3.81	.63	.43	3.34	2.44	1.56	.38	5/16-18	7.50	8	5/8-11	20	28
5	125	7.62	2.23	4.83	5.07	5.12	4.32	.75	.51	3.63	—	1.75	.50	3/8-16	8.50	8	3/4-10	23	39
6	150	8.62	2.23	5.88	5.57	5.62	4.32	.75	.51	3.63	—	1.75	.50	3/8-16	9.50	8	3/4-10	30	44
8	200	10.81	2.40	7.80	6.94	7.12	4.29	.87	.63	3.63	—	1.75	.50	3/8-16	11.75	8	3/4-10	43	67
10	250	13.06	2.75	9.78	8.56	8.47	5.50	1.18	.87	4.28	—	2.19	.56	1/2-13	14.25	12	7/8-9	76	106
12	300	15.42	3.08	11.74	10.18	9.97	5.50	1.18	.87	4.28	—	2.19	.56	1/2-13	17.00	12	7/8-9	119	163
14	350	17.27	3.73	12.90	11.95	14.00	7.75	1.38	.39x.39	2.50	5.00	3.13	.69	5/8-11	18.75	12	1-8	202	262
16	400	19.50	4.11	14.68	12.94	16.75	10.38	1.97	.39x.47	3.50	7.12	4.38	1.00	3/4-10	21.25	16	1-8	291	378
18	450	21.38	4.61	16.97	14.15	19.00	10.38	1.97	.39x.47	3.50	7.12	4.38	1.00	3/4-10	22.75	16	1 1/8-8	382	478
20	500	23.62	5.03	18.86	15.26	21.75	10.38	2.50	.62x.62	5.00	7.12	4.38	1.00	3/4-10	25.00	20	1 1/8-8	640	756
24	600	27.96	6.00	22.73	18.21	24.25	15.38	3.00	.75x.75	4.75	11.25	6.63	1.50	1-8	29.50	20	1 1/4-8	992	1183
30†	750	34.50	7.50	29.25	21.12	27.88	19.50	3.50	.88x.62	6.13	—	4.50	2.00	1 1/4-7	36.00	28	1 1/4-8	1382	1691
36†	900	40.25	8.26	35.00	25.28	27.45	12.76	3.75	.88x.62	10.00	—	5.25	2.50	1 1/4-7	42.75	32	1 1/2-8	1850	2405
42†	1050	45.00	9.51	40.00	29.00	43.25	19.50	4.50	1.0x.75	6.13	—	6.00	3.00	1 1/2-6	49.50	36	1 1/2-8	3706	4222

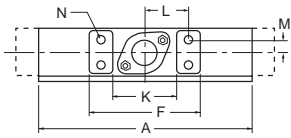

ANSI 300 Series 42

Series 43 WEIGHTS

Valve Size ins	mm	A	B	C	D	E	F	G	H*	J	K	L	M	N	Lug Bolting Data			Series 42	Series 43
															BC	No. Holes	Threads UNC-2B		
2 1/2	65	4.75	1.88	2.28	3.00	4.29	3.81	.63	.43	3.34	2.44	1.56	.38	5/16-18	5.88	8	3/4-10	13	18
3	80	5.25	1.88	2.86	3.25	4.54	3.81	.63	.43	3.34	2.44	1.56	.38	5/16-18	6.63	8	3/4-10	15	19
4	100	6.72	2.03	3.72	4.38	5.41	3.81	.63	.43	3.34	2.44	1.56	.38	5/16-18	7.88	8	3/4-10	20	28
5	125	8.25	2.23	4.82	5.07	5.63	4.32	.75	.51	3.63	—	1.75	.50	3/8-16	9.25	8	3/4-10	28	39
6	150	8.88	2.42	5.68	6.25	6.37	4.25	.87	.63	3.63	—	1.75	.50	3/8-16	10.62	12	3/4-10	34	61
8	200	10.94	2.82	7.45	7.55	7.72	5.50	1.18	.87	4.28	—	2.19	.56	1/2-13	13.00	12	7/8-9	55	103
10	250	13.26	3.28	9.32	9.36	9.10	5.50	1.38	.39x.39	4.28	—	2.19	.56	1/2-13	15.25	16	1-8	100	162
12	300	15.42	3.62	11.20	10.89	13.00	7.75	1.38	.39x.39	2.50	—	3.13	.69	5/8-11	17.75	16	1 1/8-8	162	248
14	350	17.75	4.62	12.50	11.95	14.00	7.75	1.97	.39x.47	3.00	—	3.50	1.41	3/4-10	20.25	20	1 1/8-8	352	410
16	400	20.11	5.35	15.25	18.08	15.70	9.00	2.50	.62x.62	8.00	—	3.62	1.25	7/8-9	22.50	20	1 1/4-8	538	673
18	450	21.99	5.98	16.25	19.60	16.35	9.76	2.50	.62x.62	8.00	—	4.00	1.88	7/8-9	24.75	24	1 1/4-8	645	816
20	500	24.32	6.35	17.93	21.20	17.51	11.00	3.00	.75x.75	8.00	—	4.50	2.00	1-8	27.00	24	1 1/4-8	840	1028
24	600	29.23	7.22	21.56	19.56	24.88	19.50	3.50	.88x.62	6.13	—	5.00	2.25	1 1/4-7	32.00	24	1 1/2-8	1352	1839
30†	750	35.37	8.98	28.00	29.70	25.80	15.00	4.50	1.0x.75	10.00	—	6.00	3.00	1 1/2-6	39.25	28	1 3/4-8	1750	2850
36†	900	43.75	10.67	33.88	28.00	32.86	12.76	5.00	1.25x.88	14.10	—	6.00	3.00	1 1/2-6	46.00	32	2-8	3700	4500

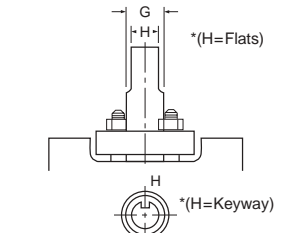
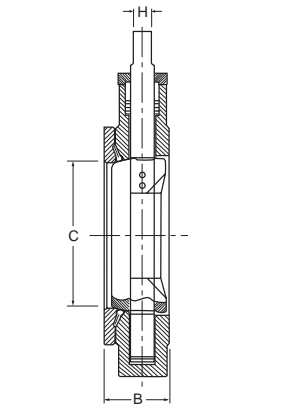
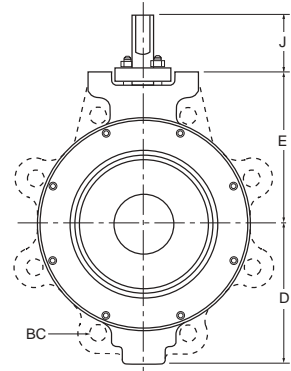

ANSI 600 Series 44

Series 45 WEIGHTS

Valve Size ins	mm	A	B	C	D	E	F	G	H*	J	K	L	M	N	Lug Bolting Data			Series 44	Series 45
															BC	No. Holes	Threads UNC-2B		
3†	80	5.75	2.30	2.90	5.90	6.26	4.37	.75	.51	3.63	2.62	1.75	.50	3/8-16	6.62	8	3/4-10	24	28
4†	100	7.00	2.77	3.80	6.86	7.28	5.00	1.00	.63	3.63	3.06	2.00	.75	3/8-16	8.50	8	7/8-9	33	41
6†	150	9.76	3.34	5.76	8.40	8.57	5.75	1.25	.87	4.27	3.38	2.25	1.00	1/2-13	11.50	12	1-8	80	103
8†	200	12.00	4.23	7.62	11.40	9.25	7.12	1.75	.39x.39	6.00	4.00	2.81	1.25	5/8-11	13.75	12	1 1/8-8	157	196
10†	250	14.17	4.82	9.75	14.35	11.66	8.50	2.00	.39x.47	6.50	4.62	3.50	1.41	3/4-10	17.00	16	1 1/4-8	265	326
12†	300	16.50	5.51	11.38	16.04	13.22	9.00	2.25	.39x.47	6.50	5.00	3.62	1.69	7/8-9	19.25	20	1 1/4-8	375	492
14†	350	18.20	6.09	12.50	17.74	14.57	9.75	2.50	.62x.62	8.00	5.25	4.00	1.88	7/8-9	20.75	20	1 3/8-8	496	658

Dimensions are in inches and weights in lbs.

†Note: For mounting of actuators and manual gear operators, dimensions are for reference only. Consult factory for exact dimensions. Bray reserves the right to change product dimensions without notice.

*Keyway is applicable on valve sizes 14"-42" Class 150, 10"-36" Class 300, and 8"-14" Class 600.

C_v VALUES-VALVE SIZING COEFFICIENT

ANSI 150 Series 40 / 41

Valve Size		Disc Position (degrees)								
ins	mm	90°	80°	70°	60°	50°	40°	30°	20°	10°
2½	65	160	136	100	78	50	30	16	8	3
3	80	185	178	155	123	87	56	32	14	4.8
4	100	375	365	315	250	175	115	63	31	10
5	125	790	675	500	360	238	146	78	41	16
6	150	1350	1070	750	510	330	218	140	81	35
8	200	2800	2230	1590	1060	685	456	280	165	65
10	250	4300	3450	2430	1630	1050	700	450	250	100
12	300	6650	5330	3750	2530	1630	1080	700	390	155
14	350	7650	6100	4300	2900	1890	1250	810	450	175
16	400	9800	7860	5510	3700	2420	1530	1020	580	230
18	450	10500	9100	6960	5100	3520	2220	1180	500	170
20	500	13500	11700	8800	6500	4500	2820	1530	640	200
24	600	20000	17100	12800	9570	6640	3880	2200	920	240
30	750	32000	27300	20900	15500	10700	6700	3600	1510	320
36	900	48500	41100	31700	23200	16400	10200	5430	2260	480
42	1050	65000	58000	46100	35000	25000	16000	9000	3700	700

ANSI 300 Series 42 / 43

Valve Size		Disc Position (degrees)								
ins	mm	90°	80°	70°	60°	50°	40°	30°	20°	10°
2½	65	160	136	100	78	50	30	16	8	3
3	80	185	178	155	123	87	56	32	14	4.8
4	100	375	365	315	250	175	115	63	31	10
5	125	790	675	500	360	238	146	78	41	16
6	150	1000	875	710	530	370	240	138	79	26
8	200	2000	1720	1360	950	630	405	240	121	47
10	250	2650	2250	1740	1200	780	510	295	150	61
12	300	4000	3400	2500	1690	1100	710	430	220	92
14	350	3900	3300	2400	1570	1000	630	390	220	90
16	400	7800	6540	4550	2970	1840	1160	730	420	180
18	450	9500	8000	6170	4530	3110	1970	1080	440	94
20	500	11000	9570	7300	5400	3720	2330	1250	530	110
24	600	18000	15100	11400	8570	5920	3700	2000	830	180
30	750	29000	24400	18900	13700	8500	6000	3230	1330	290
36	900	45000	38100	29200	21000	14800	9100	4660	1730	380

ANSI 600 Series 44 / 45

Valve Size		Disc Position (degrees)								
ins	mm	90°	80°	70°	60°	50°	40°	30°	20°	10°
3	80	185	178	155	123	87	56	32	14	4.8
4	100	375	365	315	250	175	115	63	31	10
6	150	1000	875	710	530	370	240	138	79	26
8	200	1865	1585	1200	880	600	370	195	78	14
10	250	2650	2250	1740	1200	780	510	295	150	61
12	300	4000	3400	2500	1690	1100	710	430	220	92
14	350	3900	3300	2400	1570	1000	630	390	220	90

PRESSURE / TEMPERATURE

ANSI 150 Series 40 / 41

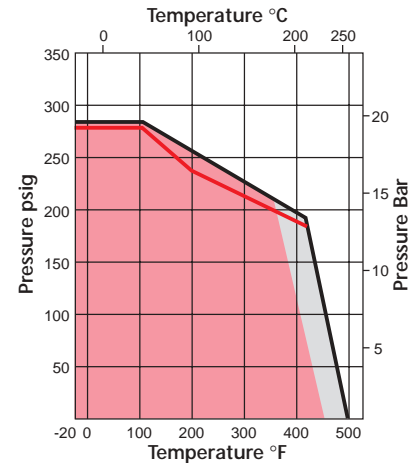

ANSI 300 Series 42 / 43

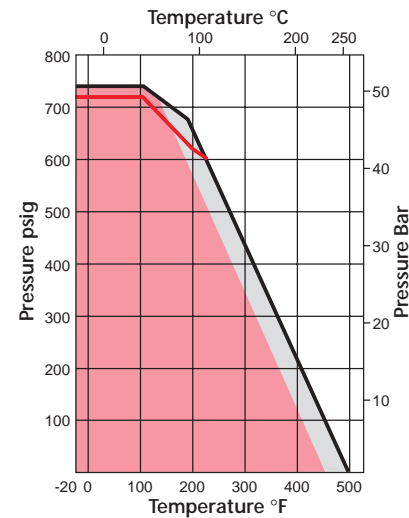

ANSI 600 Series 44 / 45

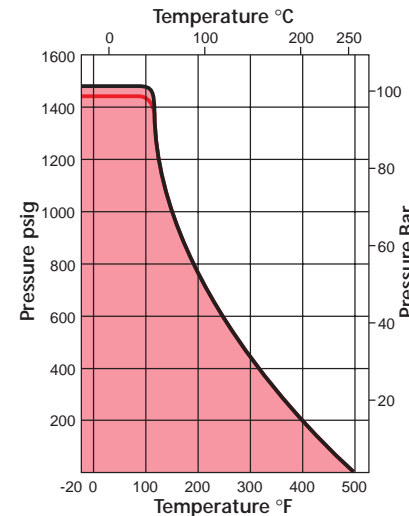

- Carbon Steel Bodies
- Stainless Steel Bodies
- RTFE and PTFE Seats
- RTFE Seats Only

C_v is defined as the volume of water in U.S.G.P.M. that will flow through a given restriction or valve opening with a pressure drop of one (1) p.s.i. at room temperature. Recommended control angles are between 25°–70° open. Preferred angle for control valve sizing is 60°–65° open.

ANSI 150 Series 40 / 41 Standard

Valve Size	System Pressure ΔP (PSIG)							
	Less than 150		150 – 200		200 – 250		250 – 285	
ins	Torque	Flow*	Torque	Flow*	Torque	Flow*	Torque	Flow*
2 1/2	200	350	240	360	280	390	300	400
3	220	350	260	360	300	390	320	400
4	320	350	370	360	420	390	460	400
5	650	360	800	400	940	450	1040	500
6	810	400	960	480	1100	550	1200	600
8	1500	800	1720	880	1950	960	2100	1000
10	2800	1200	3300	1300	3760	1400	4100	1500
12	4100	2000	5000	2200	5900	2400	6500	2500
14	6300	2500	7400	2800	8500	3100	9500	3400
16	9100	3500	11300	4200	13500	4900	15000	5200
18	14000	5300	17000	5700	20000	6100	22000	6300
20	18000	6500	21300	6900	24700	7300	27000	7500
24	29000	7600	34600	8100	40100	8600	44000	8800
30	47000	10000	53700	11900	67700	13800	75000	15000
36	64000	16000	81000	19700	98000	23400	110000	26000
42	83000	25000	105000	30000	127000	35000	143000	40000

ANSI 150 Series 40 / 41 with Fire Safe Seats

ins	Torque	Flow*	Torque	Flow*	Torque	Flow*	Torque	Flow*
2 1/2	720	1000	770	1040	810	1080	840	1100
3	780	1000	830	1040	870	1080	900	1100
4	900	1200	980	1310	1050	1420	1100	1500
5	1500	1300	1630	1410	1750	1520	1850	1600
6	1750	1400	1880	1510	2000	1620	2100	1700
8	2800	1800	2950	1950	3100	2100	3200	2200
10	4200	2500	4530	2760	4860	3020	5100	3200
12	6900	4000	7350	4300	7790	4600	8100	4800
14	17000	4600	18100	5050	19200	5500	20000	5800
16	18000	6000	19850	6800	21700	7600	23000	8200

ANSI 300 Series 42 / 43 Standard

Valve Size	System Pressure ΔP (PSIG)							
	Less than 150		150 – 350		350 – 550		550 – 740	
ins	Torque	Flow*	Torque	Flow*	Torque	Flow*	Torque	Flow*
2 1/2	200	350	360	460	510	550	670	640
3	220	350	380	460	530	550	690	640
4	320	350	530	470	730	580	1000	680
5	650	360	1250	500	1850	630	2550	820
6	1000	390	1650	640	2300	880	3000	1100
8	1850	780	3100	920	4300	1060	5300	1200
10	3300	1100	5500	1600	7600	2100	10000	2600
12	5000	2000	8300	2700	11500	3400	15000	4000
14	8600	2200	13400	3000	18300	3800	22000	4500
16	14000	3500	21500	4200	29000	4900	38000	5600
18	18000	3800	27000	5200	36100	6600	45000	7900
20	24000	4500	36700	6200	49300	7900	61000	9500
24	38000	7200	57000	9200	76700	11200	95000	13000
30	83000	7800	127000	12500	172000	17200	210000	21700
36	119000	10000	180000	18000	240000	28000	290000	34000

ANSI 300 Series 42 / 43 with Fire Safe Seats

ins	Torque	Flow*	Torque	Flow*	Torque	Flow*	Torque	Flow*
2 1/2	720	1000	860	1100	1010	1200	1100	1300
3	800	1000	950	1100	1100	1200	1200	1300
4	900	1200	1200	1300	1500	1400	1700	1500
5	1500	1500	2300	1650	3100	1800	3600	1850
6	2100	1800	2900	2000	3700	2200	4300	2400
8	3150	2400	4300	2500	5500	2600	6200	2700
10	7300	3200	10200	3340	13000	3480	15000	3600
12	11000	4000	14700	4240	18400	4480	21000	4700
14	19000	4100	24000	4370	26000	4640	28000	4900
16	42000	7800	48200	8200	54400	8600	57000	9000

SEATING/UNSEATING TORQUES (Lb. – Ins.)

*These are the flow rates in U.S.G.P.M. before dynamic torques must be considered to determine which torque is greater (seating/unseating or dynamic torque).

Water equivalent is used. For other fluids divide the given flows by \sqrt{SG} where SG = specific gravity. For water SG = 1.

NOTE: The Seating/Unseating Torques as shown include a reasonable safety factor to cover severe conditions. For non-severe applications and with the seat retainer mounted *upstream* these torques can be reduced up to 30%. For fluids with solids or abrasive content, torque may be increased. Please consult the Bray factory.

ANSI 600 Series 44 / 45

Valve Size	System Pressure ΔP (PSIG)			
	Less than 150		150 – 600	
ins	Torque	Flow*	Torque	Flow*
3	480	760	870	850
4	960	1100	1600	1200
6	1700	1400	3200	1500
8	4100	3100	7200	3300
10	8300	3400	14000	3600
12	11800	4100	12000	4300
14	15000	4200	24000	4500

Valve Size	System Pressure ΔP (PSIG)			
	600 – 1050		1050 – 1480	
ins	Torque	Flow*	Torque	Flow*
3	1200	1100	1450	1100
4	2100	1400	2700	1400
6	4600	1900	5800	2100
8	10100	3500	14000	3500
10	18000	3800	24000	4300
12	26000	4500	30000	4500
14	33000	4500	43000	4800

Item Name	Material
1 Body	Stainless Steel, ASTM A351 GR CF8M Carbon Steel, ASTM A216 GR WCB / A516 GR 70
2 Disc	Stainless Steel, ASTM A351 GR CF8M – Standard with Electroless Nickel Plating on disc edge – <i>FIRE SAFE</i>
3 Stem	17-4 PH SS, ASTM A564-Type 630
4 Taper Pin	17-4 PH SS, ASTM A564-Type 630
5 Disc Spacers	316 Stainless Steel, ASTM 276 Type 316
6 Bearing Assembly	316 Stainless Steel with TFE & Glass Fabric Liner
7 Gland Ring	316 Stainless Steel, ASTM 276 Type 316
8 Stem Seal	PTFE rings plus 1 Carbon Fiber ring – Standard Valve Flexible Graphite rings – <i>FIRE SAFE</i> Valve
9 Thrust Washer	316 Stainless Steel, ASTM 276 Type 316
10 Gland Retainer	316 Stainless Steel, ASTM A351 CF8M Carbon Steel, ASTM A216 GR WCB / A516 GR 70
11 Stud	316 Stainless Steel, ASTM A193-B8M
12 Lock Washer	18-8 Stainless Steel
13 Hex Nut	18-8 Stainless Steel
14 Seat Assembly	RTFE [^] with Silicone Rubber O-ring PTFE with Silicone Rubber O-ring
15 Seat Retainer Plate	316 Stainless Steel, ASTM A351 CF8M / A276-316 Carbon Steel, ASTM A516 GR 70
16 Cap Screws	18-8 Stainless Steel Alloy Steel
17 O-Ring Gasket	PTFE – Standard Valve Flexible Graphite – <i>FIRE SAFE</i> Valve
18 Locating Plug	316 Stainless Steel, ASTM 276 Type 316 Carbon Steel, Phosphate Coated
19 Metal Seat ^{‡‡}	Inconel [®] 718, ASTM B670
20 Gasket ^{‡‡}	Flexible Graphite

Not Shown: Bellville Washer and Grounding Washer: 18-8 Stainless Steel, for 14"–42" Class 150, 14"–36" Class 300 and 10"–larger Class 600 valves

[^]RTFE is supplied by Bray as RPTFE (reinforced polytetrafluoroethylene).

^{‡‡} *FIRE SAFE* Valve only.

Other materials are available, please consult factory for your specific application.

Exploded View
Series 40

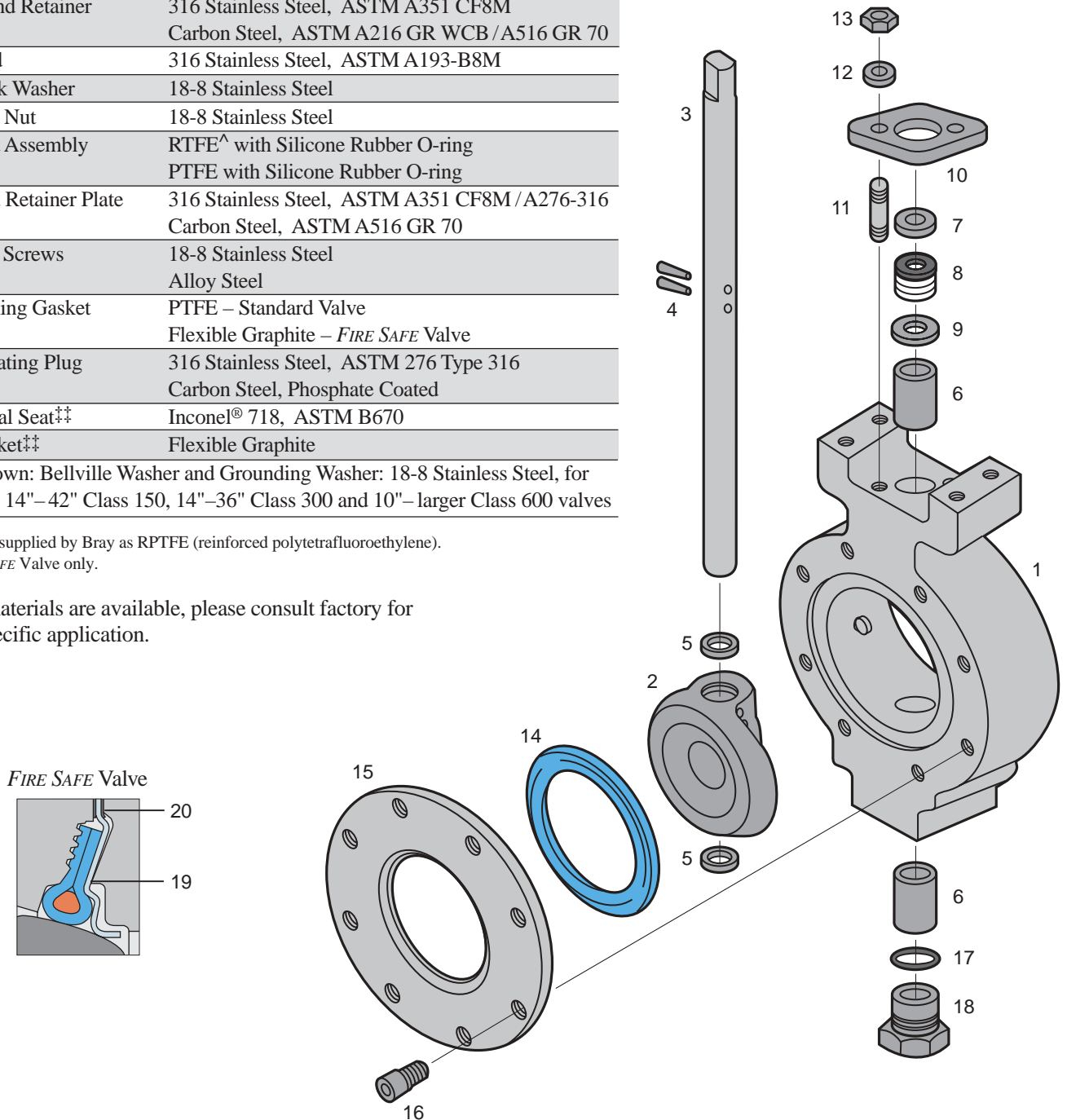



IN ADDITION TO THE EXCELLENT FEATURES OF THE SERIES 40, THIS HIGH PERFORMANCE BUTTERFLY VALVE OFFERS SUPERIOR ADVANTAGES OVER OTHER VALVES.

When matched against comparably rated plug, globe, gate, ball and diaphragm valves, the reduced weight and space requirements of the Series 40 is readily apparent.

The cost savings of installation and maintenance are substantial.

The torque requirements of the High Performance Series 40 Butterfly Valve are also significantly less. For example, an 8" Series 40 Class 150 valve weighs 45 lbs. and has a maximum torque of 1,500 in/lbs. Comparable plug valves weigh 319 lbs. with 12,500 in/lbs. of torque, and ball valves weigh 158 lbs. with 6,400

in/lbs. of torque. A gate valve with a comparable rating weighs 310 lbs. and requires a linear unit for actuation. Therefore, the Series 40 Butterfly Valve requires a much smaller actuator than other valves.

Economy, efficiency and proven superior performance establish the Bray/McCannalok as the premier solution for demanding high pressure applications.



DIRECT MOUNTING OF COMPACT, HIGH TORQUE BRAY PNEUMATIC AND ELECTRIC ACTUATORS PROVIDE LOW COST AUTOMATION FOR ON-OFF AND CONTROL SERVICES.

The Series 40 valves can be automated inexpensively with Bray's pneumatic and electric actuators. These actuators fully complement the Bray/McCannalok and directly mount without the need for large brackets or adapters. Bray has designed the most advanced, highest quality line of actuators and Brayline accessories available today.

At left, a Series 90 pneumatic actuator mounted to a 6" Series 40 valve. At right, a Series 70 electric actuator is shown mounted to a 6" Series 40 valve.



DISTRIBUTOR

All statements, technical information, and recommendations in this bulletin are for general use only. Consult Bray representatives or factory for the specific requirements and material selection for your intended application. The right to change or modify product design or product without prior notice is reserved.



A Division of BRAY INTERNATIONAL, Inc.
13333 Westland East Blvd. Houston, Texas 77041
281.894.5454 FAX 281.894.9499 www.bray.com

Bray® is a registered trademark of BRAY INTERNATIONAL, Inc.
© 2003 Bray International. All rights reserved. B-1023 11/03