

## BALLOMAX® PN16 / 25, DN 65 - 250

### Materialebeskrivelse

helsvejset stålkugleventil

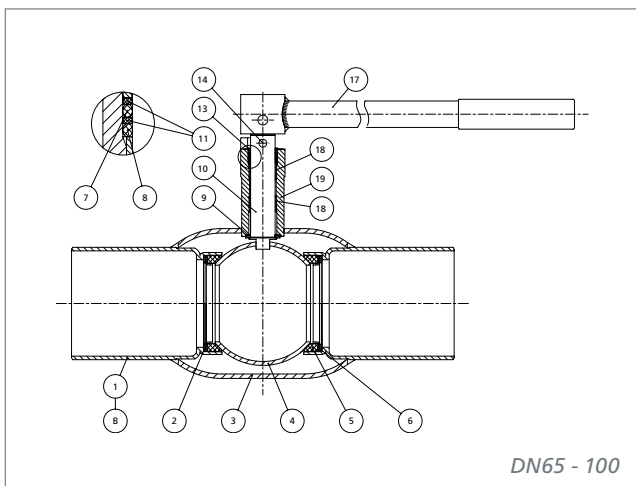

DN65 - 100

### Material Description

Fully welded steel ball valve

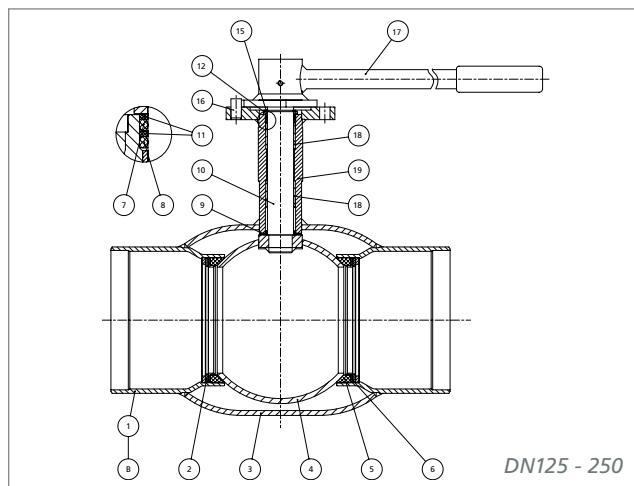

DN125 - 250

	Benævnelse	Materiale	Article	Material
1	Svejseende	Stål St 37.0	Welding end	Steel St 37.0
1B	Flange	Stål R St 37-2	Flange	Steel R St 37-2
2	Fjederskive	Fjederstål 50 Cr V4 <sup>1)</sup>	Disc spring	Spring steel 50 Cr V4 <sup>1)</sup>
3	Ventilhus	Stål St 37.0	Body	Steel St 37.0
4	Kugle	Rustfrit stål CF 8 / AISI 304	Ball	Stainless steel CF 8 / AISI 304
5	Sædepakning	PTFE, 20% C	Body seat	PTFE, 20% C
6	Støttering	Rustfrit stål AISI 304	Back-up ring	Stainless steel AISI 304
7	O-ring	EPDM	O-ring	EPDM
8	O-ring	FPM/FKM <sup>2)</sup>	O-ring	FPM/FKM <sup>2)</sup>
9	Friktionspakning	PTFE, 20% C	Friction packing	PTFE, 20% C
10	Spindel	Rustfrit stål W nr. 1.4305	Stem	Stainless steel W No. 1.4305
11	Støttering	PTFE, 20% C	Back-up ring	PTFE, 20% C
12	Dækskive	Stål ELZ	Cover disc	Steel ELZ
13	Mellemring	Rustfrit stål AISI 304 L / 1.4305	Intermediate ring	Stainless steel AISI 304 L / 1.4305
14	Kærvstift	Rustfrit stål W nr. 1.4104	Slotted pin	Stainless steel W Nr. 1.4104
15	Segerring	Fjederstål	Segger circlip	Spring steel
16	Stopstift	Stål	Stop pin	Steel
17	Håndtag	Stål	Handle	Steel
18	Radialleje	Stålbøsning m. PTFE	Radial bearing	Steel bush with PTFE
19	Spindelstyr	Stål St 52 / ST 37.0	Stem guide	Steel St 52 / ST 37.0
	<sup>1)</sup> DN 250	Fjederstål 51 Cr V4	<sup>1)</sup> DN 250	Spring steel 51 Cr V4
	<sup>2)</sup> DN 250	EPDM	<sup>2)</sup> DN 250	EPDM

## BALLOMAX® PN25, DN 65 - 500

### Betjeningsmomenter

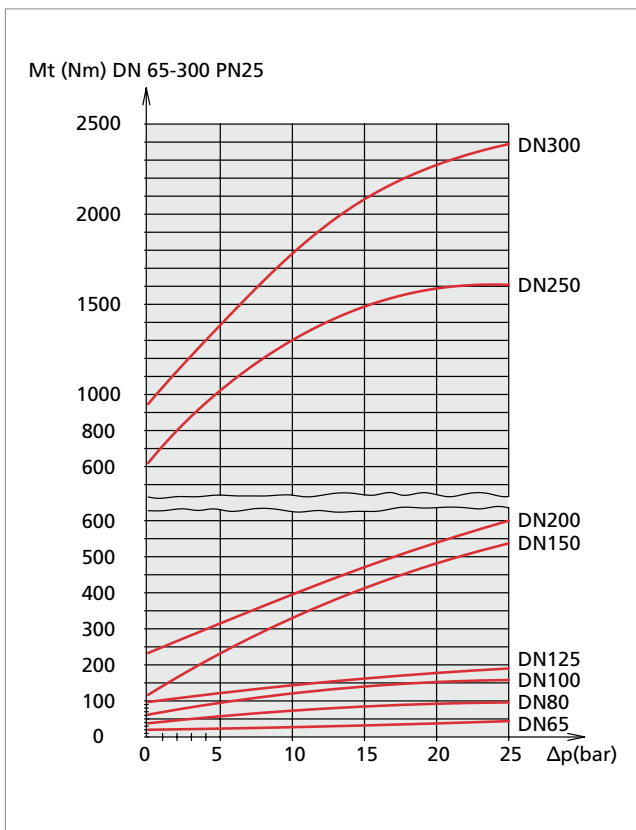

De angivne betjeningsmomenter er vejledende og fremkommet ved måling af fabriksnye ventiler. Momentet er at forstå som et løsrivelsesmoment gældende for en afspærret, men nyligt aktiveret ventil.

Efter lang stilstandstid kan de angivne værdier blive faktor 1.5 større.

### Operating Torque

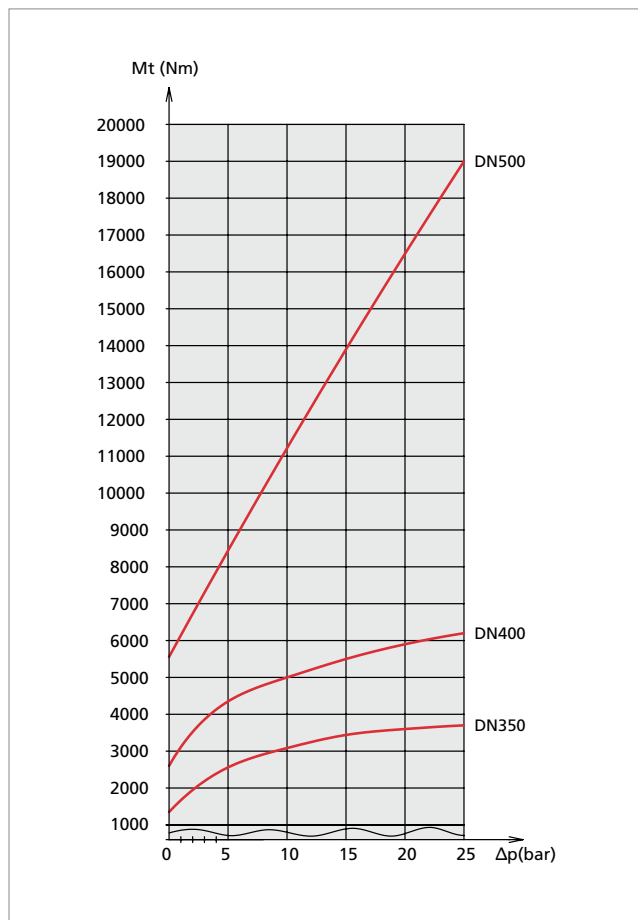

The torques stated are for guidance only; they have been obtained by measuring on new ball valves. The torque is to be understood as the pull-off torque applicable for a closed, but recently activated ball valve.

The values stated may rise to a factor of 1.5 after a long period of not being in service.

## BALLOMAX®

### Tryktabsdiagram

### Pressure Drop Graph

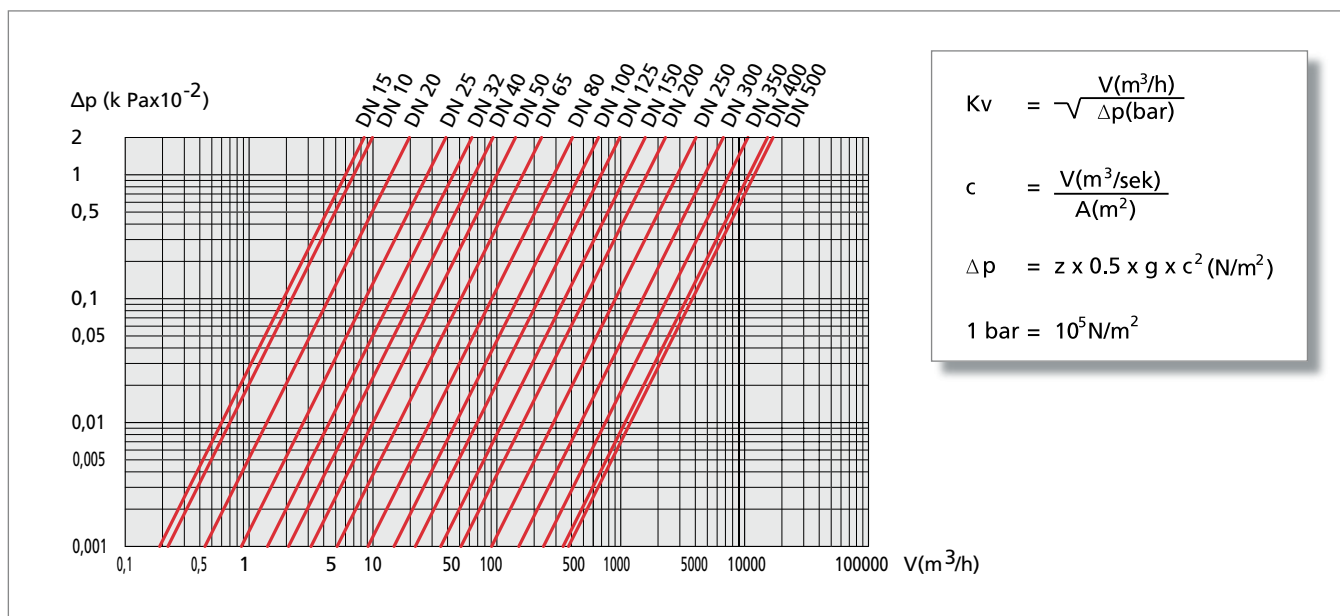

Kugleventil i helt åben position  
 Medie: vand med  
 massefylde 1000 kg/m<sup>3</sup>

Ball valve in fully open position.  
 Medium: water  
 Density in 1000 kg/m<sup>3</sup>

### Begrebsforklaringer

- Kv: Det antal m<sup>3</sup> vand i timen, der løber igennem en given ventil ved et trykfald på 1 bar.
- c: Mediets strømningshastighed i m/sek.
- V: Det aktuelle flow.
- A: Den aktuelle ventils gennemstrømningsareal i m<sup>2</sup>.
- z: Modstandskoefficient
- g: Mediets massefylde i kg/m<sup>3</sup>

### Definitions

- Kv: m<sup>3</sup> water per hour at pressure drop 1 bar.
- c: Flowrate of the media in m/sec.
- V: Actual flow volume.
- A: The area of flow in m<sup>2</sup> of the ball valve in question.
- z: Coefficient of resistance.
- g: Density in kg/m<sup>3</sup>.

DN	10	15	20	25	32	40	50	65	80	100	125	150	200	250	300	350	400	500
<b>Kv</b>	7	6	14	26	43	64	100	160	280	450	690	1100	1500	2770	4620	7250	10540	11780
<b>Ax10<sup>-4</sup></b>	0.79	0.79	1.77	3.14	4.90	8.04	12.56	19.63	33.18	50.27	78.54	122.72	176.71	314.16	490.87	706.86	962.11	1256.6
<b>z</b>	0.32	0.44	0.41	0.37	0.33	0.40	0.40	0.39	0.36	0.32	0.33	0.32	0.35	0.33	0.29	0.24	0.22	0.21