

# Reflex valve level indicator

U 48.1-4p4

PN 40

Note:

Z positions are drawn turned through 90° angle

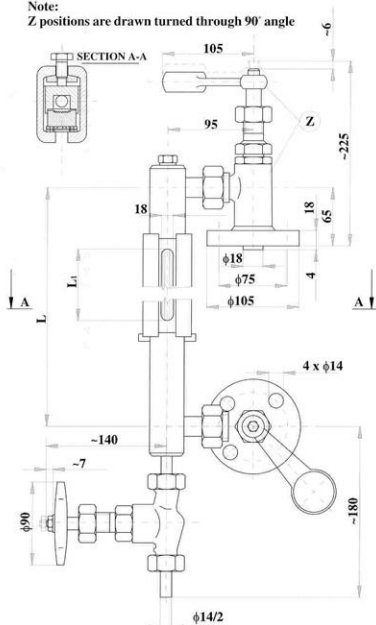

## Application

It is used as water direct-reading instrument for steam-generator tanks or for fixed hot-water bin, for service pressures up to PN 25 and temperatures up to 250°C. The indicator must not be used for toxic, aggressive or crystalline substances.

## Technical description

Level indicator has upper and inferior head, groove with reflex glass, and control valve V 10 151 4100 DN 10. Head comprises protective ball cap and quick-closing, arm controlled valve with weight.

Level indicator enables max. groove inclination 30°. Control valve is for venting and sludging, when the level indicator is shut-down. Reflex glasses enable contrast fluid level observation.

## Connecting and face-to-face dimensions

Connecting and face-to-face dimensions are given in the table below.

## Material

Holder head body	carbon steel
Level indicator glass	cast tempered glass
Stem, plug	stainless steel

## Installation

Level indicator is installed vertically or to a sloping position with the control valve in low position.

L	L <sub>1</sub>	kg
1000	690	22,5
1200	730	23,0
1400	750	26,5