

# Yoke gate valve

## S 38.1 111(3)-2100

## S 38.1 121(3)-2100

### PN 100

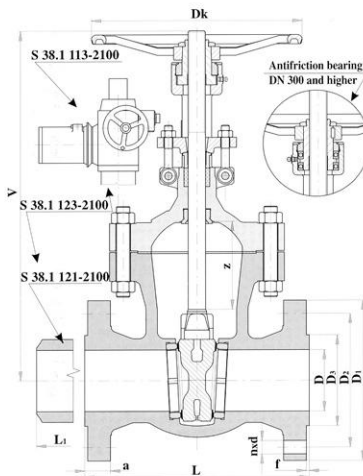

#### Application

Shut-off valve for water, saturated and superheated steam, gases, non-aggressive liquids, crude oil and oil products with temperature 200°C up to 550°C (according to material used). Use of the valve for other media must be discussed with the supplier in advance. The gate valve is not suitable for flow regulation.

Temperature [°C]	Pressure [MPa]
200	12,50
300	12,00
400	10,60
450	9,95
500	7,77
550	3,42

#### Technical description

The yoke gate valve has a rising non-rotating stem with its thread outside the valve chamber. The stem nut is turned to raise or lower the stem and flexible wedge. Seats and wedge have stainless steel welded sealing surfaces. The seats are screwed into valve body. Stem is sealed with gland packing in a bonnet. Gate valves can be provided also with a drain plug, vent plug or bypass.

#### Connecting and face-to-face dimensions

Flange connection dimensions as per DIN 2501 and DIN 2526, butt-weld ends as per ČSN 13 1075. Face-to-face dimension as per ČSN EN 558, end to end dimensions as per ČSN 13 3053. Basic face-to-face and connecting dimensions are shown in the table.

#### Material

Body, bonnet, wedge 42 2744.5  
 Stem stainless steel (13 Cr)  
 Seats steel 15 128.5  
 Sealing surfaces stellite  
 Gland packing asbestos-free graphite  
 Alternative materials per DIN standards are also available.

#### Testing

The gate valve is tested per ČSN 13 3060, part 2.

#### Installation

The gate valve can be installed in horizontal, vertical or oblique piping. For electrically actuated valves, the axis of electric motor must remain horizontal. If the servomotor is installed or from a vertical axis upwards, amount of oil fill must be increased. If the valve is installed horizontally, the actuator must be supported.

#### Operation

The gate valve can be operated by handwheel, chainwheel, electric servomotor (S38.1 113, S38.1 123) or from a stand.

DN	D	D <sub>1</sub>	D <sub>2</sub>	D <sub>3</sub>	a	f	n	d	L	L <sub>1</sub>	V	z	Dk	kg
50	50	195	145	102	30	3	4	26	250	250	370	72	200	42
65	65	220	170	122	34	3	8	26	290	290	440	85	250	59
80	80	230	180	138	36	3	8	26	310	310	465	92	250	61
100	100	265	210	162	40	3	8	30	350	350	540	117	300	105
125	125	315	250	188	40	3	8	33	400	400	635	150	300	163
150	150	355	290	218	44	3	12	33	450	450	805	170	500	275
200	200	430	360	278	52	3	12	36	550	550	865	225	500	434
250	250	505	430	340	60	3	12	39	650	650	1060	275	630	689
300	300	585	500	402	68	4	16	42	750	750	1184	330	630	1000
350	350	655	560	460	74	4	16	48	850	850	1400	375	710	1153
400	400	715	620	518	78	4	16	48	950	950	1545	435	710	1435
500	500	870	760	630	94	4	20	56	1150	1150	1870	540	800	2900
600	600	990	875	740	104	4	20	62	1350	1350	2180	630	900	4010