

Yoke gate valve

S 38.1 111(3)-240B

S 38.1 121(3)-240B

PN 40

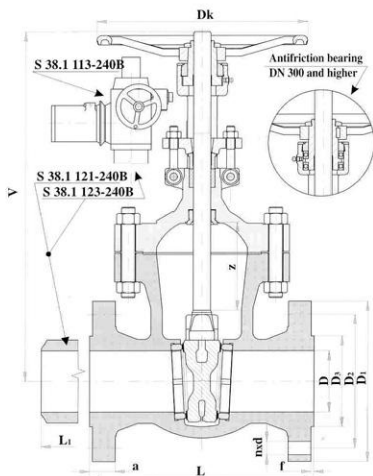

Application

Shut-off valve for water, saturated and superheated steam, gases, non-aggressive liquids, crude oil and oil products. With temperature of -50°C up to 400°C (according to material used). Use of the valve for other media must be discussed with the supplier in advance. The gate valve is not suitable for flow regulation.

Temperature [°C]	Pressure [MPa]
-50	5,09
-20	5,09
200	5,09
300	4,66
400	4,66

Technical description

The yoke gate valve has a rising non-rotating stem with its thread outside the valve chamber. The stem nut is turned to raise or lower the stem and flexible wedge. Seats and wedge have stainless steel welded sealing surfaces. The seats are screwed into valve body. Stem is sealed with gland packing in a bonnet. Gate valves can be provided also with a drain plug, vent plug or bypass.

Connecting and face-to-face dimensions

Flange connection dimensions as per DIN 2501 and DIN 2526, butt-weld ends as per ČSN 13 1075. Face-to-face dimension as per ČSN EN 558, end to end dimensions as per ČSN 13 3053. Basic face-to-face and connecting dimensions are shown in the table.

Material

Body, bonnet, wedge	42 2714.9
Stem	stainless steel (13 Cr)
Seats	steel 11 503.1
Sealing surfaces	18-8CrNi
Gland packing	asbestos-free graphite
Alternative materials per DIN standards are also available.	

Testing

The gate valve is tested per ČSN 13 3060, part 2.

Installation

The gate valve can be installed in horizontal, vertical or oblique piping. For electrically actuated valves, the axis of electric motor must remain, horizontal. If the servomotor is installed or from a vertical axis upwards, amount of oil fill must be increased. If the valve is installed horizontally, the actuator must be supported.

Operation

The gate valve can be operated by handwheel, chainwheel, electric servomotor (S38.1 113, S38.1 123) or from a stand.

DN	D	D ₁	D ₂	D ₃	a	f	n	d	L	L ₁	V	z	Dk	kg
50	50	165	125	102	20	3	4	18	250	250	360	72	200	27
65	65	185	145	122	22	3	4	18	290	290	440	85	250	38
80	80	200	160	138	24	3	8	18	310	310	465	92	250	44
100	100	235	190	162	24	3	8	22	350	350	520	117	250	56
125	125	270	220	188	26	3	8	26	400	400	635	150	300	101
150	150	300	250	218	28	3	8	26	450	450	705	170	400	125
200	200	375	320	285	34	3	12	30	550	550	840	225	450	223
250	250	450	385	345	38	3	12	33	650	650	988	280	500	383
300	300	515	450	410	42	4	16	33	750	750	1122	330	500	520
350	350	580	510	465	46	4	16	36	850	850	1242	365	560	700
400	400	660	585	535	50	4	16	39	950	950	1417	420	630	910
500	500	755	670	615	52	4	20	42	1150	1150	1720	520	710	1448
600	600	890	795	735	60	5	20	48	1350	1350	2030	625	800	2600